

Table of Contents

◆ About Mongtec.....	1
◆ Trusted by Global Machine Tool Leaders.....	3
-Turn-Mill Tooling-	
◆ Driven Tools.....	8
◆ Static Toolholders.....	11
◆ Customized Special Driven Toolholders.....	12
◆ Swiss Type Toolholders.....	13
-Broaching Units-	
◆ Broaching Units.....	14
-Angle Heads-	
◆ Angle Heads	17
-Quick Change Collet Chucks-	
◆ Quick Change Collet Chucks.....	20
-Expanding Mandrels-	
◆ Expanding Mandrels.....	24
-Face Drivers & Live Centers-	
◆ Face Drivers.....	27
◆ Live Centers.....	30
◆ Custom Live Centers.....	31
-Tool Holders-	
◆ Tool Holders.....	32
◆ Tool holder cleaning device.....	36
-CNC Machining Accessories-	
◆ Zero Nuts.....	38
◆ Grippers.....	39
◆ Spindle Test Bars	40
◆ Jet Spindles.....	41
◆ CNC Machining Accessories.....	42
◆ Maintenance Service.....	43

About Mongtec

About Mongtec Precision (Est. 1983)

Founded in 1983, Mongtec Precision began in footwear manufacturing and later transitioned to focus on high-performance machine tool components as Taiwan's machining industry evolved.

Today, we specialize in driven tool holders and peripheral systems for mill-turn machining centers, offering thousands of precision-engineered products—such as VDI/BMT tool holders, quick-change chucks, 5-axis holders, angle heads, speed increasers, and hydraulic bar pullers.

Our solutions are trusted in industries including automotive, aerospace, medical, optics, and energy.

We partner with leading manufacturers from Germany, Italy, Switzerland, the U.S., Japan, South Korea, and China. We are continuously expanding our reach to serve clients globally.

Guided by German and Japanese standards, we are committed to innovation, precision, and quality—helping our clients enhance efficiency, improve product quality, reduce costs, and strengthen their competitive edge.

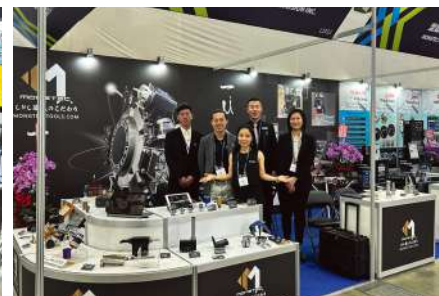

About Mongtec

Our Philosophy & Mission

“The true value of machining tools lies in performance, not price.”

“The true value of machining tools lies in performance, not price.”

At Mongtec, we believe in creating value through precision, innovation, and engineering excellence—not price competition. Our mission is to help clients enhance the intrinsic value of

their products, enabling them to lead with quality and build sustainable, competitive business models.

We actively engage in global trade shows and technical forums to stay at the forefront of industry trends. Through continuous collaboration and knowledge exchange, we integrate the latest technologies and best practices into our solutions—ensuring Mongtec remains a trusted name in high-precision machining worldwide.



Trusted by Global Machine Tool Leaders

Through the DMG MORI Qualified Products (DMQP) program, we offer an integrated manufacturing solution, ensuring fair and transparent pricing from a single source. As a certified partner of DMG MORI - DMQP and DN SOLUTIONS - DNVP, Mongtec collaborates directly with both companies to deliver globally recognized quality. These partnerships give customers access to advanced technologies, competitive pricing, and dependable worldwide support.

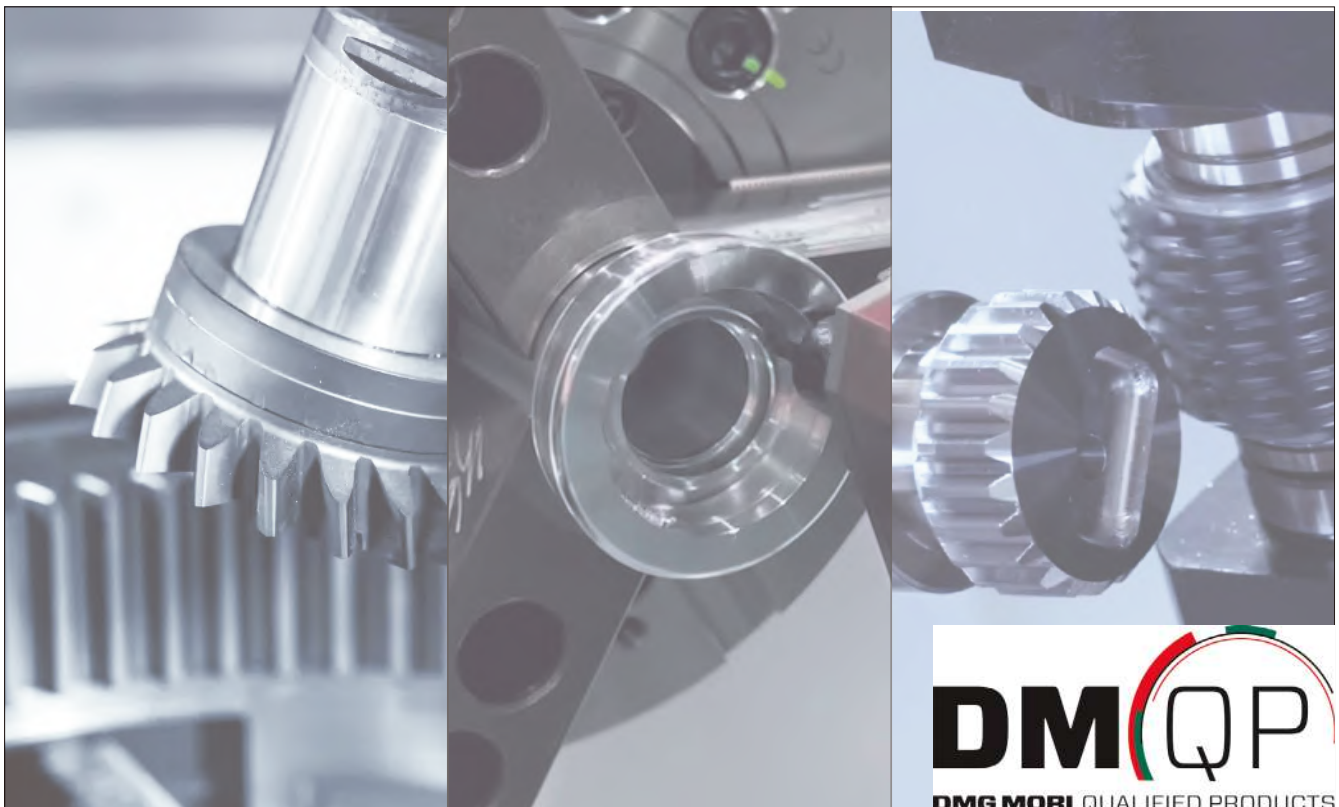

Trusted by Global Machine Tool Leaders



Trusted by Global Machine Tool Leaders

Our products and services have earned the trust of leading machine tool brands worldwide. Through strict quality control, continuous technological innovation, and reliable solutions, we help our partners enhance their competitiveness. This trust is not only a recognition of our efforts but also a driving force for our continuous pursuit of excellence.

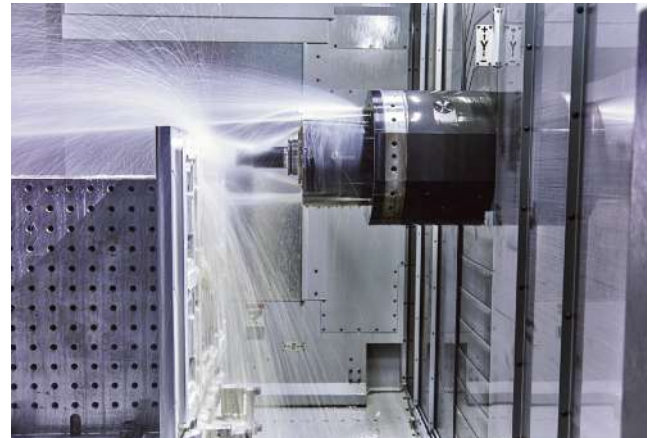

Trusted by Global Machine Tool Leaders

Recognized by leading brands such as Mazak, Okuma, and Takisawa, Mongtec's solutions are trusted worldwide. Our strict quality control, continuous innovation, and reliable support enable global machine tool makers to achieve higher performance and competitiveness.



Globally Renowned Partner Companies

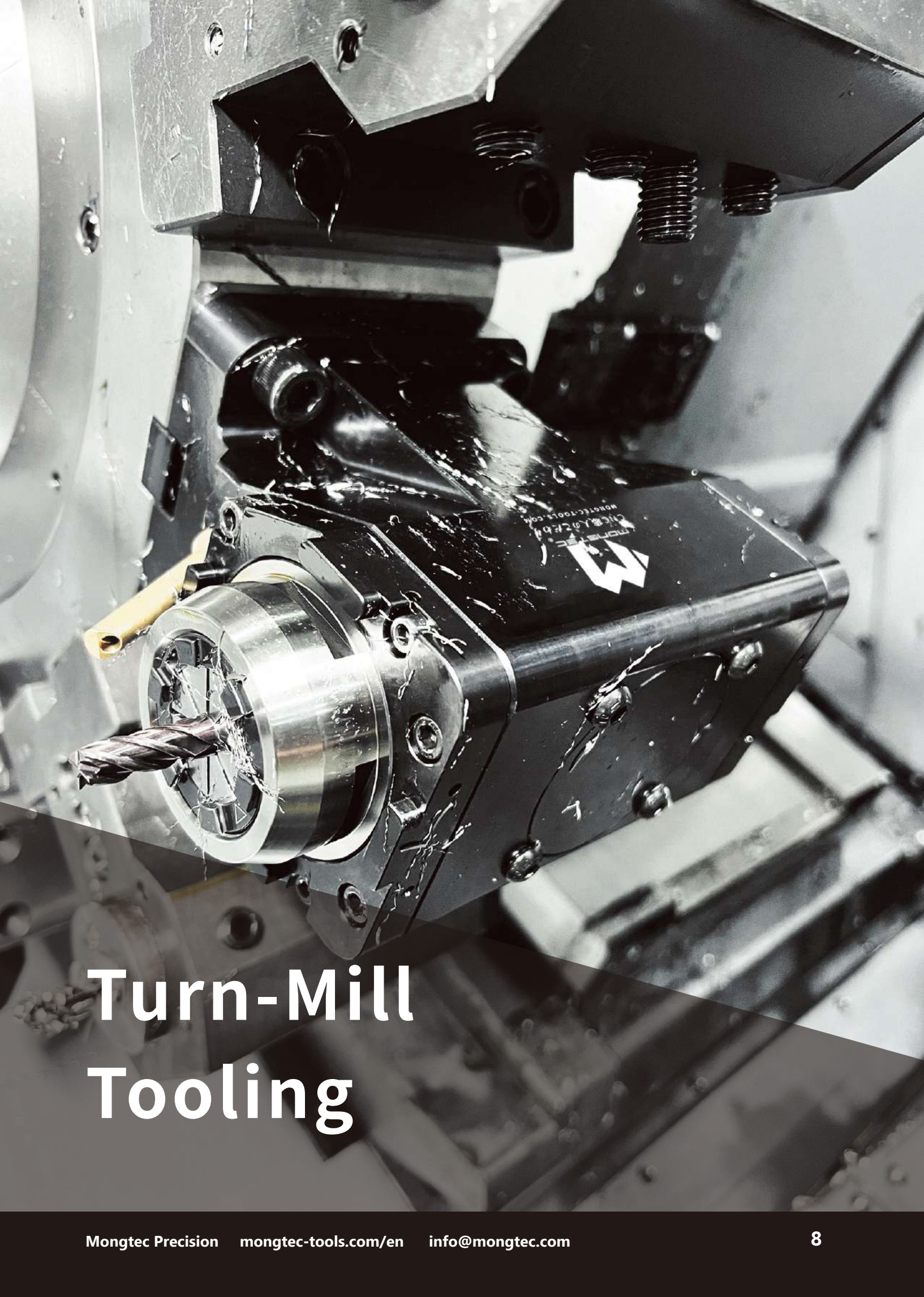

Turn-Mill Tooling

Driven Tools

Main Body

Constructed from corrosion-resistant steel with specialized surface treatment for enhanced rigidity and effective vibration damping.

Torque & Speed

- With speed increaser: Up to 32,000 rpm
- Standard speed: 6,000–12,000 rpm
- Max torque: 160 Nm

High-speed, high-torque output ensures efficient and precise machining.

Internal & External Coolant Supply

- Internal and external coolant support
- Max pressure: 100 bar

Reliable cooling for stable performance and extended tool life.

Gleason Spiral Bevel Gears

Pair-ground for high precision, smooth torque transmission, low noise, and reduced heat buildup.



Driven Tools Production Process



Material Preparation



Body Manufacturing



Spindle Manufacturing



Assembly



Input End Inspection



Output End Inspection



Packaging & Shipment

Driven Tools

Driven Tool Holder Solutions

We offer over 6,000 high-performance driven tool holder configurations, engineered for both standard and custom machining applications.

Built with ultra-rigid structures and precision engineering, our tool holders ensure exceptional stability, help reduce tooling costs, improve cutting efficiency, and shorten cycle times—ultimately enhancing productivity.

This comprehensive range supports manufacturers operating in high-precision, high-efficiency environments, delivering consistent performance and a clear competitive advantage.



0 degree driven toolholders



90 degree driven toolholders



Double 90 degree driven toolholders



Special multi-axis driven toolholders



Universal driven toolholders



Special speeder driven toolholders



Offset driven toolholder



90 degree single-side twin-spindle driven toolholder



90 degree multi-side multi-spindle driven toolholder

Static Toolholders

Mongtec static toolholders are meticulously engineered for outstanding clamping accuracy and structural rigidity, delivering consistent performance in the most demanding machining conditions. To meet a wide range of application requirements, we also provide fully customizable solutions—individually tailored to precise dimensional, functional, and operational specifications.

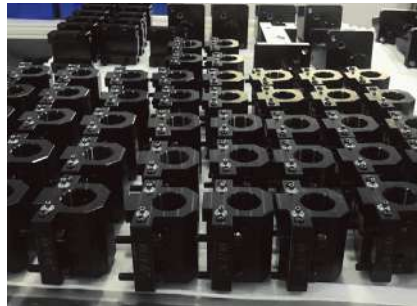

OD static toolholders



ID static toolholders



Face static toolholders



Double boring static toolholders



Double OD static toolholders



Indexed Bore Static Toolholder



Indexed Static Toolholder



Japanese-Standard Static Toolholder



Various VDI Static Toolholders

Customized Special Driven Toolholders

If your application requires a specialized toolholder solution, Mongtec offers expert customization services tailored to your exact needs.



Special internal groove driven toolholders



Heavy-Duty Extended Anti-Vibration Toolholder



Retractable 4-Axis Toolholder



Y-Axis hobbing driven Toolholder

PSC Quick Change System

- The triangular constraint taper delivers repeatable positioning accuracy within $\pm 2 \mu\text{m}$, ensuring exceptional machining stability.
- Designed to withstand high-pressure coolant up to 130 bar, it prolongs tool life while enhancing dimensional accuracy and surface quality of the workpiece.
- An integrated quick-change mechanism enables tool replacement in under 30 seconds, significantly boosting production efficiency and minimizing downtime.



Static Toolholders



Driven Tools



Swiss Type Toolholders

Mongtec Swiss-Type Toolholders incorporate a proprietary power-driven technology that ensures outstanding machining accuracy and stability—meeting the most rigorous quality standards across every component.

With a high-efficiency, multifunctional design, these toolholders are ideally suited for complex machining operations across diverse industries, significantly enhancing overall production performance.

Key Features

- **High Precision**

Runout within 0.005 mm, enabled by a precision-engineered structure for consistently stable machining quality.

- **Multifunctionality**

Capable of performing multiple operations, including milling and engraving.

- **High Efficiency**

Reduces machining time, boosts productivity, and lowers total operational costs.

- **Low Maintenance**

Robust, long-lasting construction ensures easy upkeep and reliable long-term use.

Applications : Aerospace, Medical, Automotive, Mold & Die, Precision Engineering.

Compatible with : STAR, CITIZEN, TSUGAMI, TORNOS, and other leading Swiss-type machines.



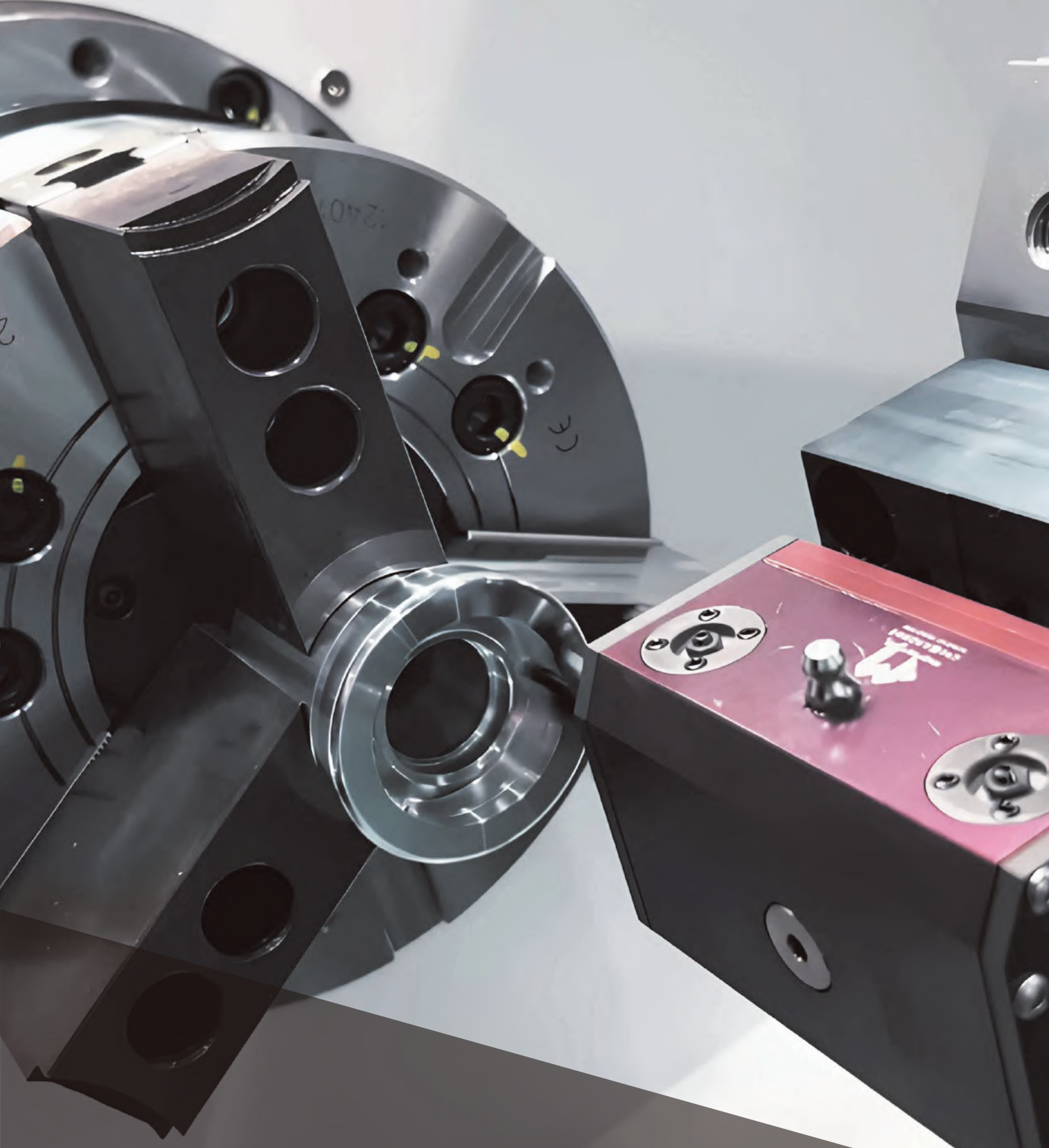

Broaching Units

Broaching Units

Gear and keyway machining can be complex—but Mongtec offers a fully integrated, one-stop solution to streamline the process.

Simply provide your machining drawings, and we'll deliver a complete plan—covering driven toolholders, tool shanks, and custom form tools—all precisely tailored to your needs.

This end-to-end approach simplifies challenging operations while boosting productivity and process reliability.

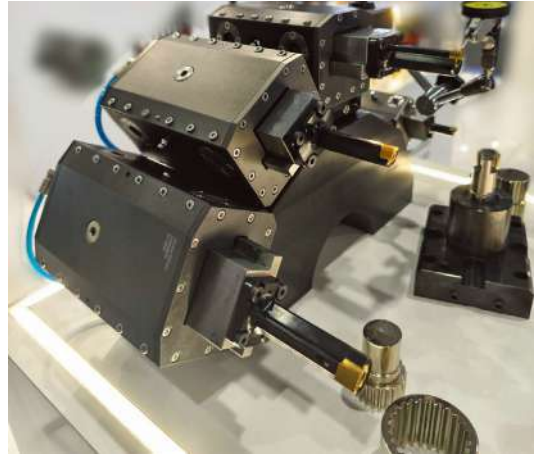

Precisely machines internal and external gears, keyways, and custom tooth profiles. Supports broaching strokes from 25 to 65 mm, meeting diverse depth and profile requirements across multiple applications.

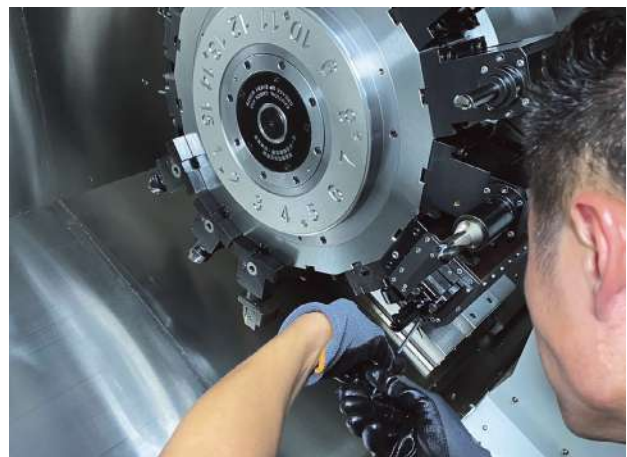
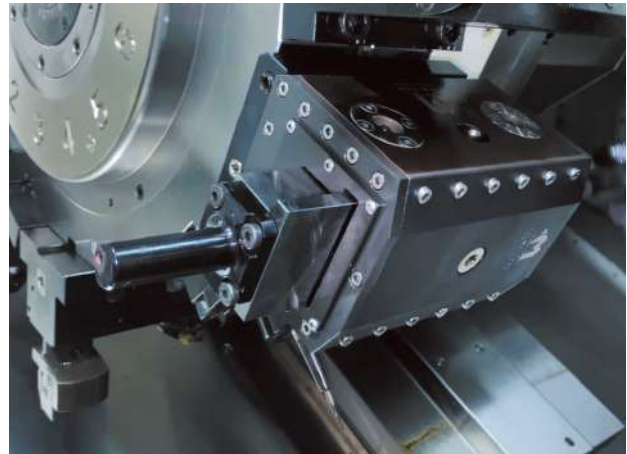

Broaching Units

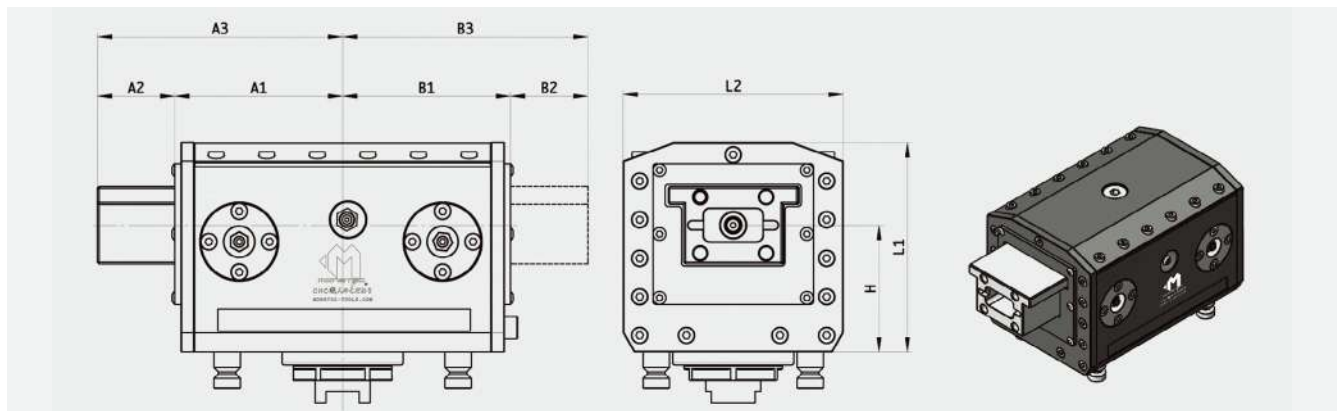
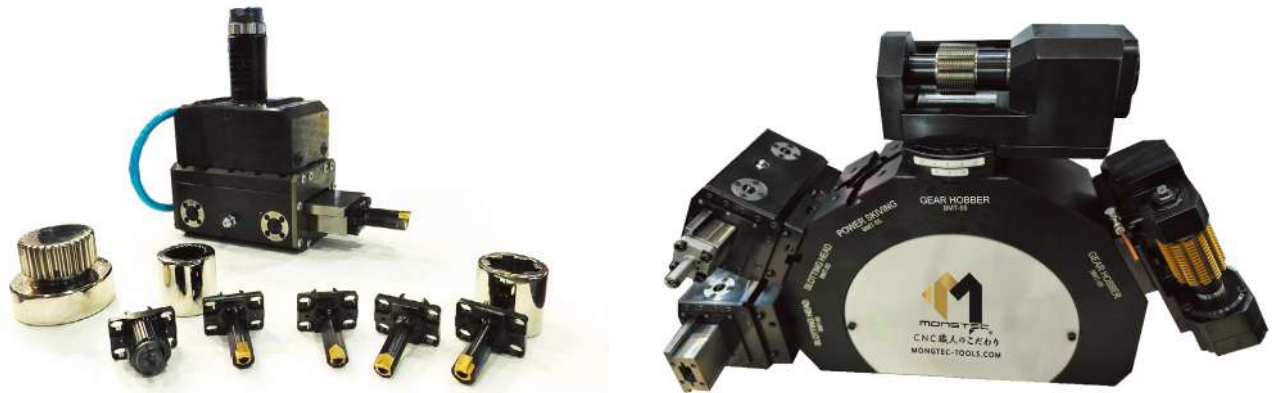

Stroke (mm)	A1 (mm)	A2 (mm)	A3 (mm)	B1 (mm)	B2 (mm)	B3 (mm)	L1 (mm)	L2 (mm)	L3 (mm)
25	50	27	77	46	27	73	52	63	30
35	76	35	111	76	35	111	95	100	58
50	91	50	141	76	50	126	95	110	58
65	106	65	171	76	65	141	97	125	57.5





Angle Heads

Angle Heads

Mongtec Angle Heads allow machining centers to perform side and angled operations with ease, offering a high cost-performance solution that enhances both flexibility and efficiency on the shop floor.

By eliminating the need for additional dedicated equipment and reducing repeated setups or part repositioning, they help minimize clamping errors—significantly improving machining accuracy, process stability, and overall productivity.



This product supports a wide range of spindle interfaces, including BT, HSK, and PSC, providing versatile compatibility across various machining sizes, orientations, and angular configurations.

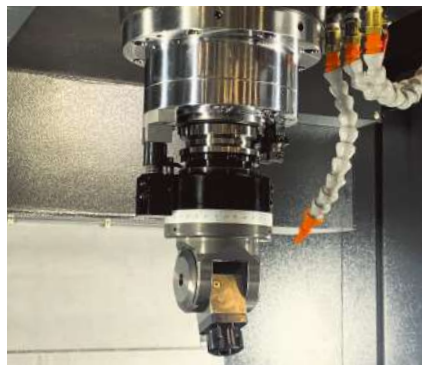

Angle Heads

Mongtec Angle Heads are designed for flexible mounting on gantry mills and various machine spindles, enabling multi-angle machining across multiple axes. Capable of milling, drilling, and boring, they offer exceptional versatility for complex parts. Engineered with high rigidity and precision, they are widely used in aerospace, automotive, mold & die, 3C electronics, and general manufacturing. By simplifying multi-axis setups, these heads enhance machining efficiency, reduce changeovers, and improve process stability—making them ideal for demanding production environments.

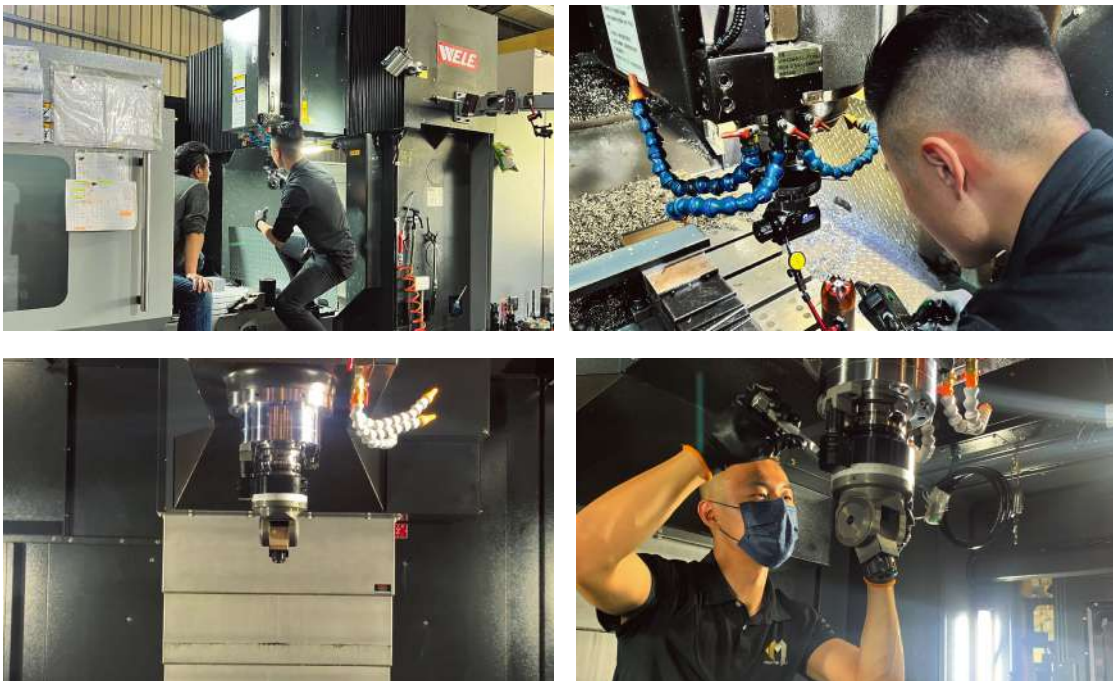

Offering a comprehensive range of standard and custom angle head solutions to meet diverse machining requirements.



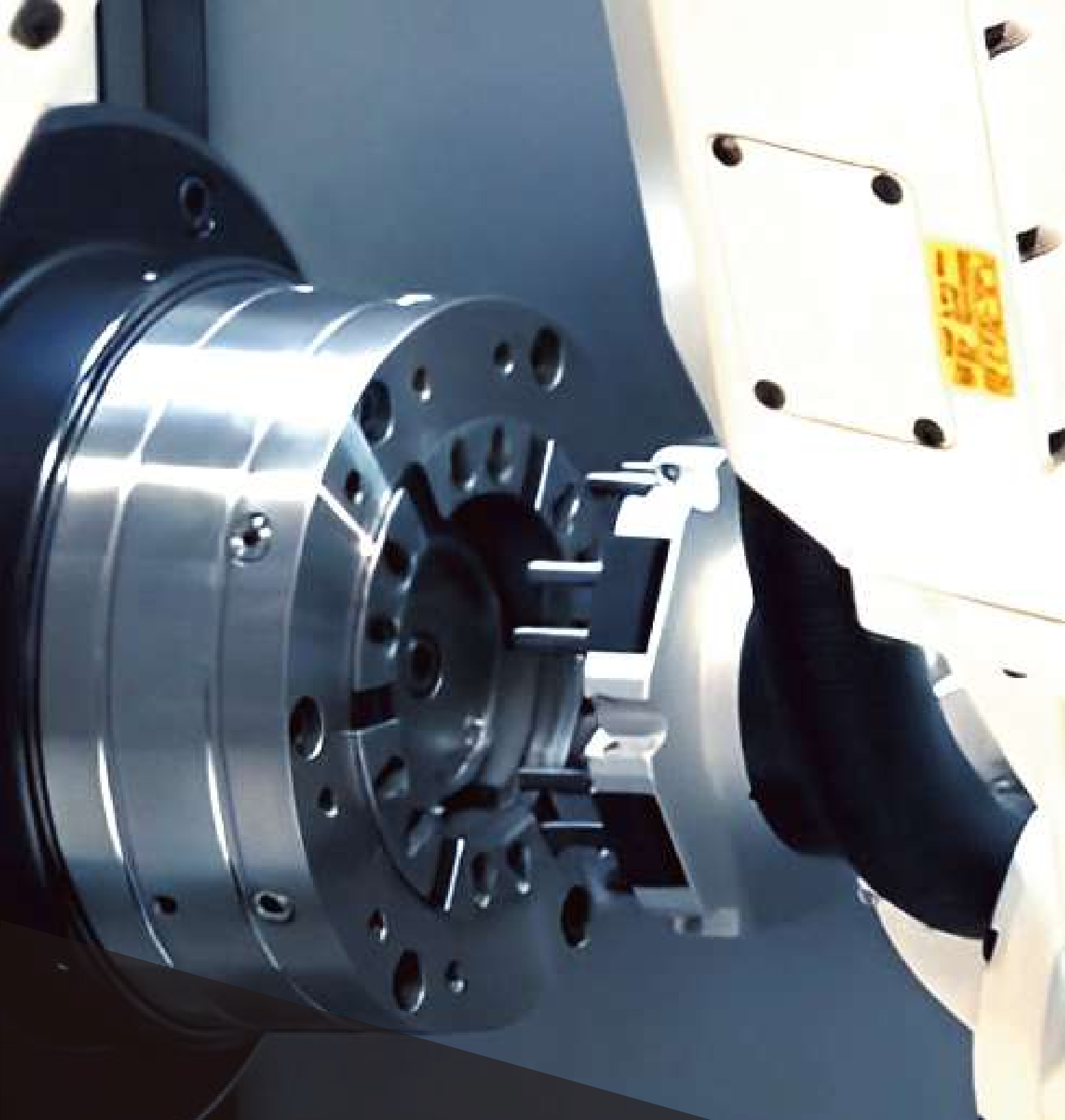

Quick Change Collet Chucks

Quick Change Collet Chucks

Mongtec fixtures are engineered for high-precision machining, rapid changeover, and exceptional stability, making them ideal for a wide range of demanding precision manufacturing applications.



High Precision & Stability

- Runout ≤ 0.005 mm ensures outstanding machining accuracy.
- High clamping force delivers stable support for both high-speed and heavy-duty cutting applications.
- A rigid structural design minimizes vibration and enhances surface finish quality.

Versatility & Flexibility

- Suitable for turning, milling, and grinding operations across a broad range of applications.
- Capable of clamping both internal and external diameters, accommodating various workpiece sizes and geometries.
- Supports a wide selection of optional accessories to meet diverse and evolving machining requirements.

Quick Changeover

- Modular design enables rapid chuck replacement, minimizing machine downtime.
- Spindle and chuck can be swapped quickly without the need for adjustment or calibration, streamlining setup and maximizing productivity.

Automation Ready

- Fully compatible with robotic arms and automated loading/unloading systems, supporting seamless integration into smart manufacturing environments.
- Can be equipped with sensor modules for real-time monitoring of clamping status, enhancing process control and operational reliability.

Custom Solutions Available

- Tailor-made fixture designs developed to address specific, complex, or non-standard machining requirements, ensuring optimal performance and integration with your production process.

High Durability & Easy Maintenance

- Constructed from wear-resistant materials to extend service life and minimize replacement frequency.
- Sealed design prevents dust and coolant ingress, ensuring long-term reliability and consistent performance in harsh machining environments.

Customized Solutions

We provide custom manufacturing services for non-standard or special-shaped clamping heads, each precisely engineered to meet your specific requirements in shape, size, and performance specifications. These tailored solutions ensure seamless compatibility with unique workpieces or specialized machining processes, delivering optimal functionality and integration into your production workflow.



Quick Change Collet Chucks

Solutions

Rubber collet clamping solution (models 32/42/52/65/80/100/120/160) for applications such as:

Ground bores, rough teeth, special Z-teeth, irregular workpieces, stepped holes, enlarged back bores, self-machining types, hexagonal shapes, and more.



Expand sleeve solution (T210/211/212/812 series products)



Solution of fixture for internal expansion lathe



Gear clamping solution



Fixture solution for machining center



Quick Change Collet Chucks

Quick-change modular solutions



Quick-change modular solutions

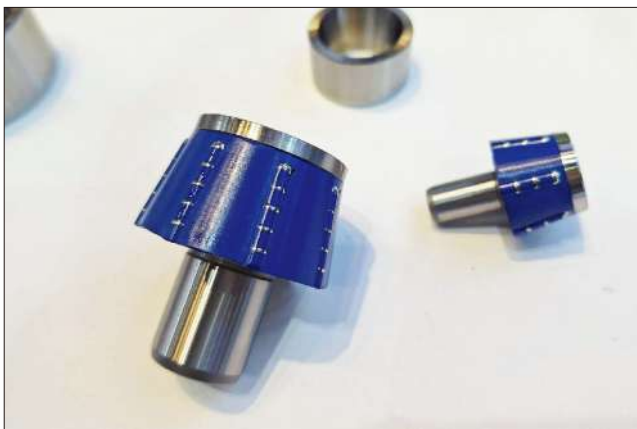

Collet Changing Tools

Easily press and release clamping heads for quick replacement in just seconds.



TYPE	32	42	52	65	80	100	125	160
------	----	----	----	----	----	-----	-----	-----



Expanding Mandrels

Expanding Mandrels



Mongtec Expanding Mandrels utilize a hydrostatic expansion mechanism, in which internal fluid pressure activates an expansion element to achieve uniform 360° elastic deformation. This ensures precise and stable clamping of workpiece bores or shafts.

Engineered for both accurate positioning and secure torque transmission, the system delivers exceptional reliability and operational safety in demanding machining environments.

Key features include:

- Interchangeable sleeves for a wide range of workpiece diameters, enabling flexible and efficient production setups.
 - A built-in elastic adjustment mechanism and quick-change design that minimize fixture setup time and enhance machine utilization.
 - Optimized for reducing manufacturing costs while maximizing machining precision and consistency
- By adopting Mongtec’s hydraulic mandrel solutions, manufacturers can unlock the full potential of their machine tools—boosting productivity and ensuring consistent, high-quality output.

Relationship Between Expansion Range and Clamping Diameter

- The maximum allowable expansion of a hydraulic mandrel must not exceed 3% of the clamping diameter.
- To ensure optimal clamping accuracy and extended service life, the clamping section of the workpiece should have a dimensional tolerance of IT7 grade or better.

Expansion Range / mm

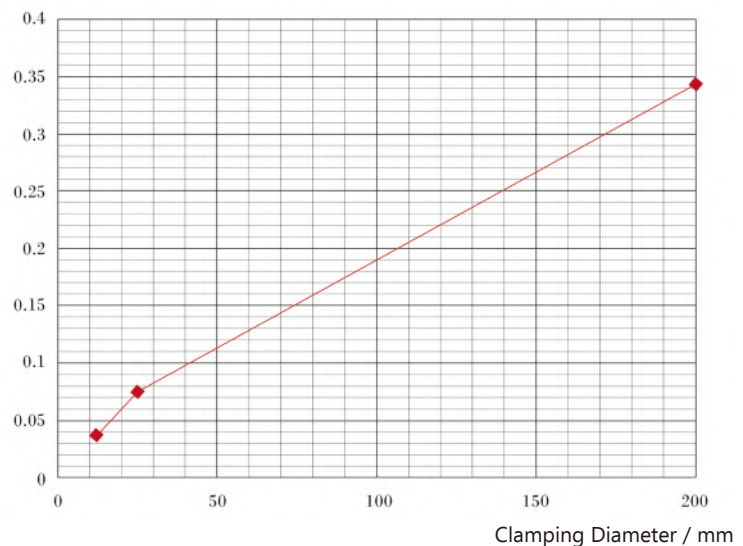

Expanding Mandrels

Gear Grinding Applications

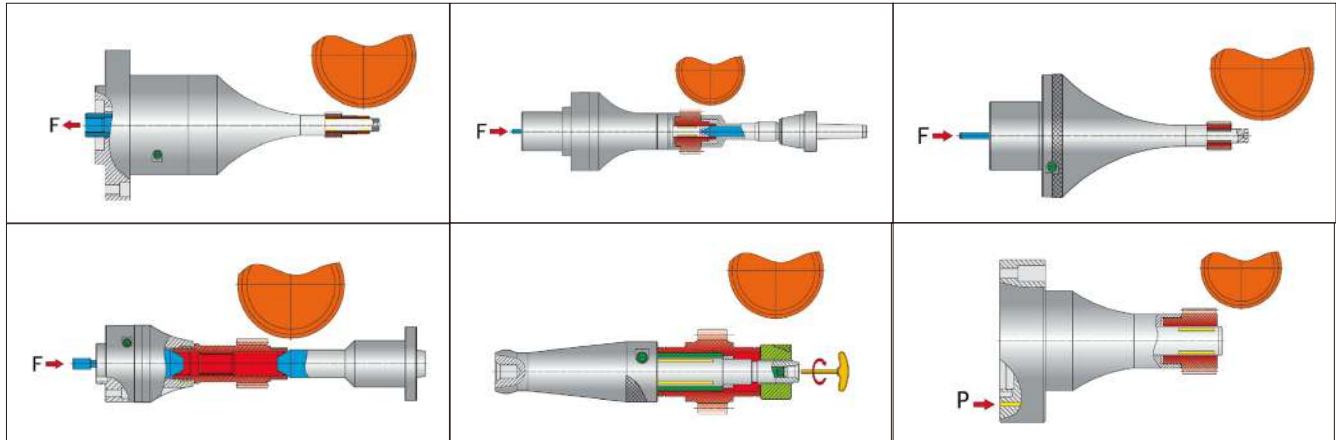

Gear Inspection Applications

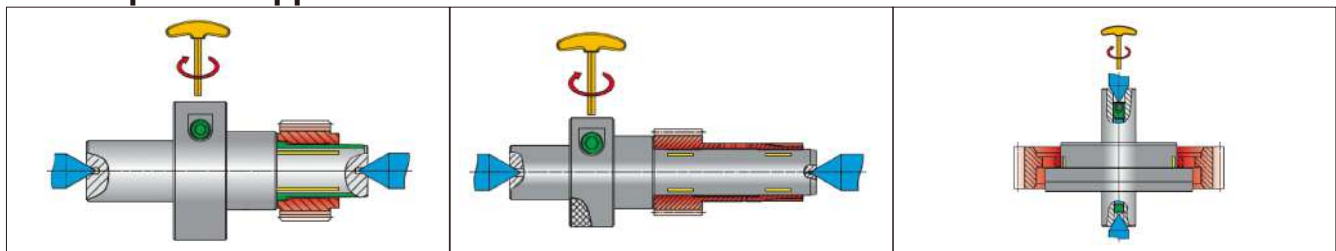

Turning Applications

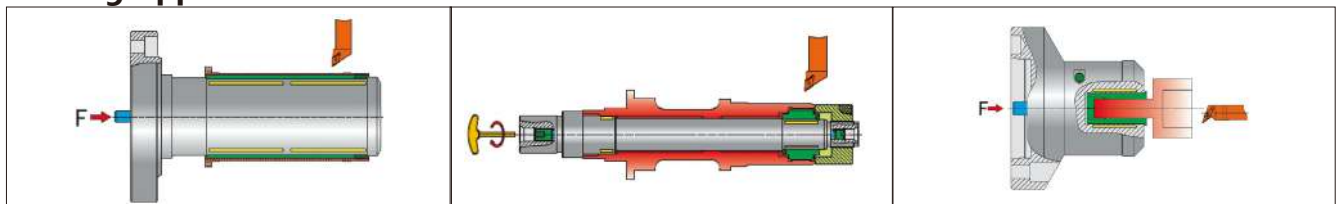

External Cylindrical Grinding Applications

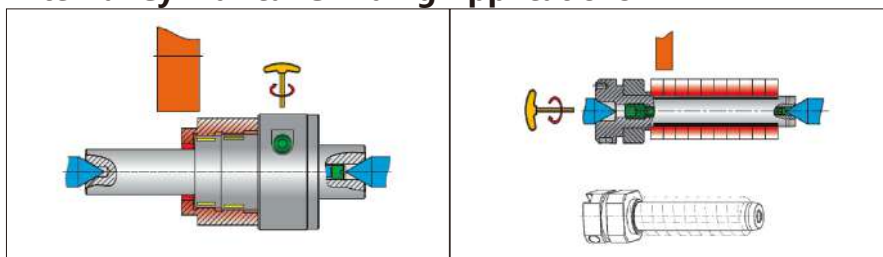

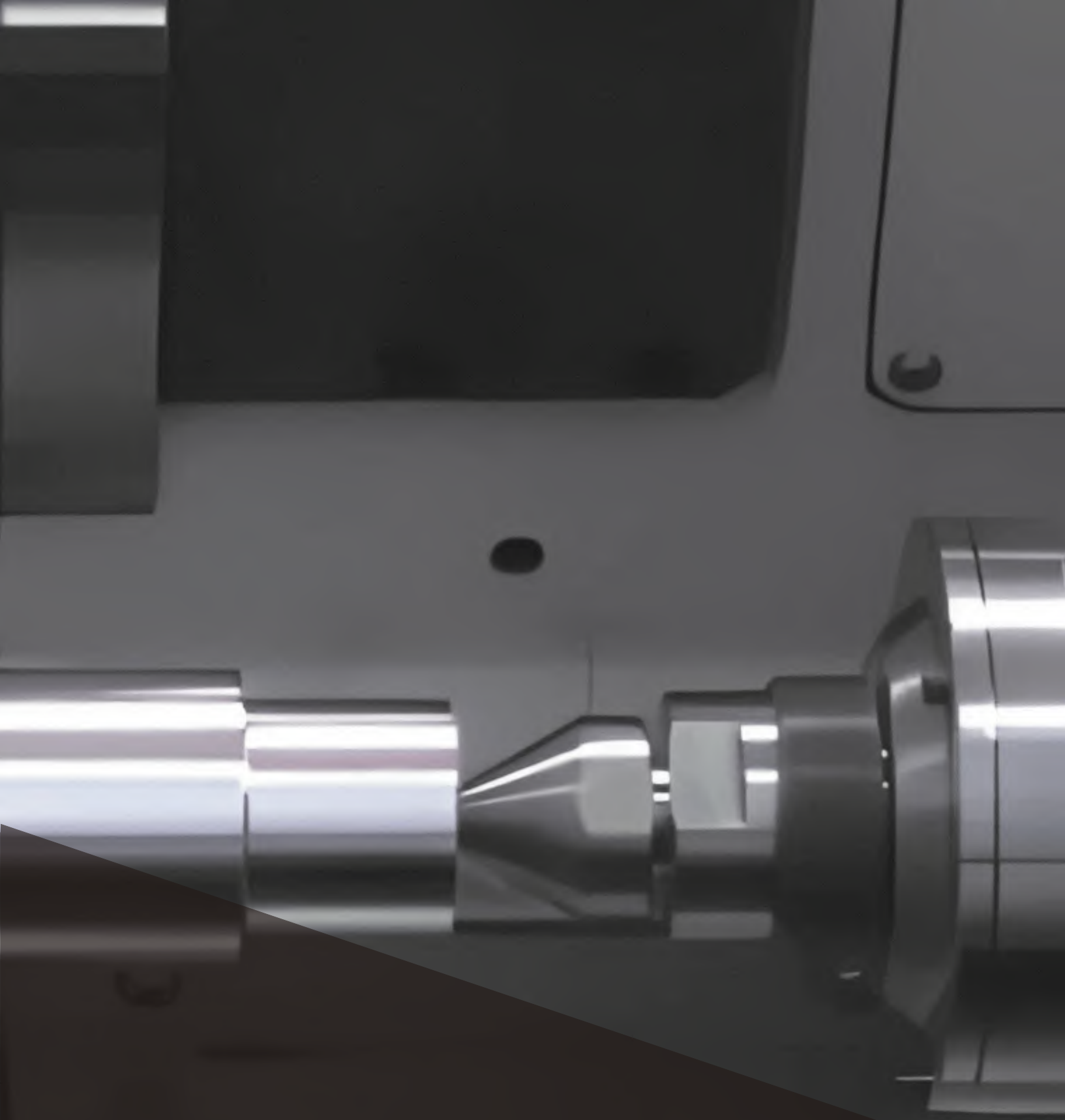

Face Drivers & Live Centers

Face Drivers

Mongtec face drivers are engineered for high-precision turning, utilizing spring-loaded or hydraulic actuation to deliver consistent axial force and secure clamping.

During spindle rotation, the center maintains constant end-face contact, transmitting torque through friction or drive elements (e.g., toothed dogs) for synchronous, slip-free rotation. This ensures superior machining stability, repeatability, and accuracy.

Our patented axial compensation system further enhances performance by automatically adjusting to irregular workpiece surfaces—ensuring a firm grip even under heavy cutting conditions.

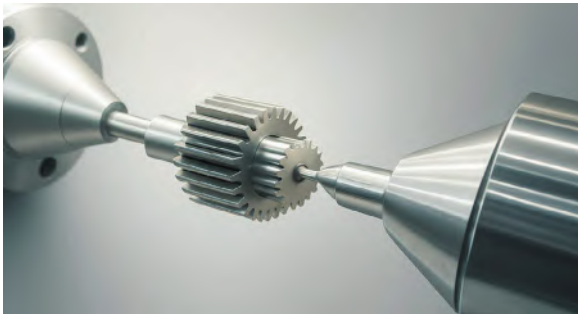

Features & Advantages of Face Drivers



- High Clamping Force & Stability**
 Delivers stable and concentric workpiece rotation through precisely controlled elastic pressure or mechanical clamping, effectively minimizing deviation and ensuring high machining accuracy throughout the operation.
- Improved Machining Accuracy**
 Significantly reduces workpiece runout, ensuring high dimensional precision and superior surface finish—resulting in enhanced product consistency and quality across production batches.
- Minimal Clamping Marks**
 Compared to conventional clamping methods, face drivers apply force more precisely and evenly, resulting in significantly reduced surface marking. This makes them particularly well-suited for precision components and high-finish workpieces where surface integrity is critical.
- Adaptable to Various Workpieces**
 Engineered to accommodate a wide variety of shapes and materials, this solution is particularly ideal for long, shaft-type components such as automotive drive shafts, machine spindles, and other precision rotational parts.
- Increased Machining Efficiency**
 Quick setup combined with stable torque transmission helps reduce cycle times, streamline operations, and significantly boost overall production efficiency.

Face Drivers

Mongtec Face Drivers

- **Auto Compensation up to 1.5 mm**

Automatically adjusts for uneven workpiece end faces, with a maximum correction range of 1.5 mm, ensuring reliable contact and stable clamping.

- **Improved Workpiece Holding**

Enhances clamping reliability, extending the service life of key components such as centers and drive pins, thereby reducing overall maintenance costs.

- **Extended Tool Life**

Stable workpiece clamping minimizes vibration and misalignment during machining, which in turn prolongs the lifespan of cutting tools.

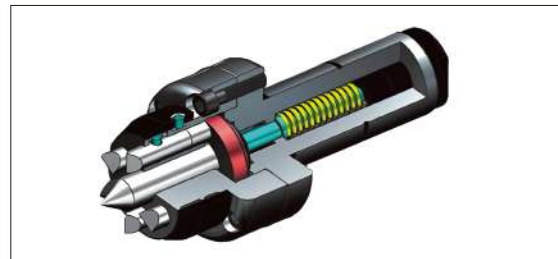

Structural Diagram



Machining Illustration

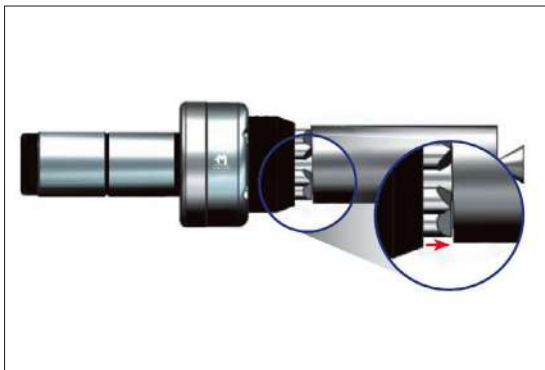

Live Centers

High-Speed Live Center

- **Equipped with High-Speed Bearings and Specialized Oil Seals**
Designed for high-speed machining operations with optimal durability and sealing performance.
- **Ideal for High-Speed Applications**
Ensures stable rotation and clamping under high RPM conditions.
- **Precision Within 0.002 mm**
Ultra-precise runout control for high-accuracy machining results.



Thrust-Sensing Live Center

- **Real-Time Monitoring of Workpiece Support Force**
Allows easy detection and adjustment of thrust to ensure optimal support during machining.
- **Minimizes Spindle Bearing Wear**
Effectively reduces long-term spindle damage caused by continuous axial impact or overload.
- **Precision Within 0.003 mm**
Ensures stable and accurate workholding for high-precision machining tasks.

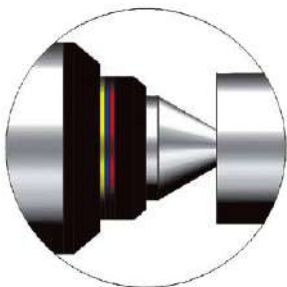

Low Thrust Pressure

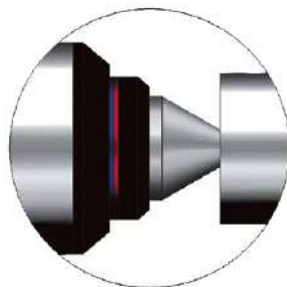

Medium Thrust Pressure

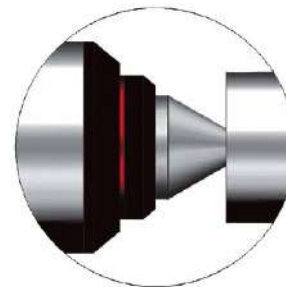

High Thrust Pressure

Color / Category	MT2(kgf)	MT3(kgf)	MT4((kgf)	MT5((kgf)
Yellow	0~500	0~500	0~1,000	0~1,500
Blue	500~1,500	500~1,500	1,000~2,000	1,500~3,000
Red	1,500~2,500	1,500~2,500	2,000~3,000	3,000~4,500

Custom Live Centers

Tailstock Adjustable Eccentric Live Center

- Use this center when the tailstock and spindle centerlines are not aligned. Alignment can be corrected via eccentric adjustment.
- Maximum eccentricity adjustment range: 2 mm
- Equipped with high-speed, high-precision bearings, ideal for precision machining at high RPMs.
- Specialized oil seal design prevents cutting fluid intrusion for long-term stability.
- All components are heat-treated to HRC 58–62 for superior impact resistance and durability.

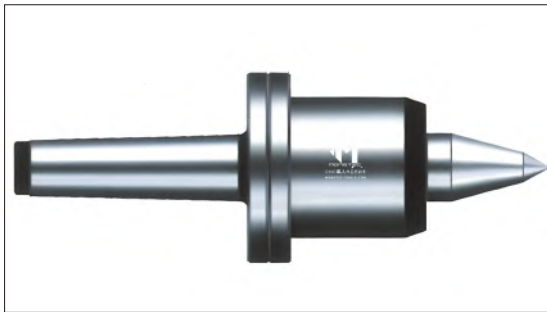

Various Custom Live Centers



speedMASTER



Tool Holders

Tool Holders

Precision Tool Holders — Engineered for 5-Axis Machining Excellence

In high-precision 5-axis machining centers, the tool holder is the critical interface between the spindle and the cutting tool—its rigidity and accuracy directly influence machining stability, repeatability, and final part quality.



Mongtec provides a comprehensive range of high-performance tool holders, available in various interface standards, clamping systems, and configurations tailored to complex machining requirements.

With precision tolerances within 0.003 mm, our tool holders are engineered to meet the demands of next-generation machining—delivering superior process reliability, surface finish, and overall productivity.



Choosing the right tool holder is key to improving machining accuracy and stability, enabling high-performance machining with greater efficiency.

Type	Standard	Key Features	Applications
BT/BBT	BT30/BT40/BT50	Commonly used on Japanese machines; offers high rigidity.	Mold and precision parts machining
HSK	HSK-A/B/C/D/E/F	Suitable for high-speed machining; features dual-face contact.	Aerospace and high-speed machining
SK	SK30/SK40/SK50	Higher precision than BT; follows German standards.	Precision mold and heavy-duty cutting
CAT	CAT30/CAT40/CAT50	North American standard; similar to BT.	General machining and aerospace
PSC	PSC32/PSC40/PSC50/PSC63	Versatile design with quick-change capability; high rigidity; ideal for heavy-duty cutting.	Mill-turn applications, aerospace, heavy cutting, and high-precision machining

Tool Holders



Choose the right clamping method to enhance machining performance and ensure high precision and rigidity.

Clamping Method	Key Features	Applicable Scope
Collet Chuck (ER Collet)	Flexible clamping, wide applicability	General machining (drilling, milling, tapping)
Pull-Back Clamping	Strong clamping force, simple structure	General milling and drilling operations
Heat Shrink Chuck	High rigidity, high precision	High-speed machining, precision mold making
Hydraulic Chuck	High precision, easy tool change	Precision machining, medical devices
Power Milling Chuck	Extremely strong clamping force, suitable for heavy cutting	Heavy cutting, high torque machining
Dual-Contact Clamping (HSK Clamp)	High-speed stability, high rigidity	5-axis machining, spindle industry
Quick-Change Tool Holder (PSC)	High rigidity, quick tool change	Aerospace, turn-mill composite machining, heavy cutting

Tool Holders

The following are partial product specifications. For other specifications or inquiries, please feel free to contact us.



Extension Tool Holder



Pull-Back Tool Holder



Heat Shrink Tool Holder



Heat Shrink Tool Holder –
Through Coolant
(Face Discharge)



ER Collet Tool Holder



Adjustable Precision Flange-
Type Tool Holder



Morse Taper Tool Holder



Threaded Morse Taper Tool
Holder



Threaded-End Tool Holder –
Straight Shank Type



Threaded-End Tool Holder –
Taper Shank Type



Side-Lock Tool Holder



Side-Lock Tool Holder –
Through Coolant
(Face Discharge)



Arbor Milling Tool Holder



Arbor Milling Tool Holder –
Inch Size



Hydraulic Tool Holder



Boring Tool Holder

Tool holder cleaning device

Tool Holder Cleaning Device

The Tool Holder Cleaning Device restores spindle and tool holder precision by effectively removing dirt and rust from the tool holder taper. This improves contact accuracy and connection stability between the spindle and tool holder, resulting in enhanced machining precision, extended tool and spindle life, and reduced risk of spindle damage.

It is an essential auxiliary device for maintaining a high-precision machining environment.

Compatible Tool Holder Types: BT, SK, CAT, HSK

Product Accessories



Before Use



After Use





CNC Machining Accessories

Zero Nuts

Zero Nuts: The Universal Secret Weapon for High-Precision Machining
 More than just a standard collet nut, the Zero Nut features six precision adjustment screws that allow for fine-tuning and correction of tool runout. Even with extended tool overhang, it provides stable control over runout, significantly enhancing the machining precision and stability of reamers, drills, end mills, and other cutting tools.

Available Sizes: ER16, ER20, ER25, ER32, ER40

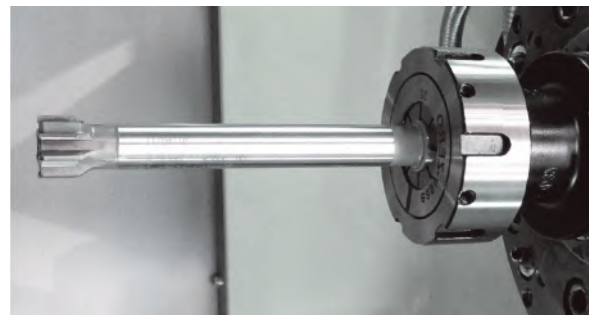
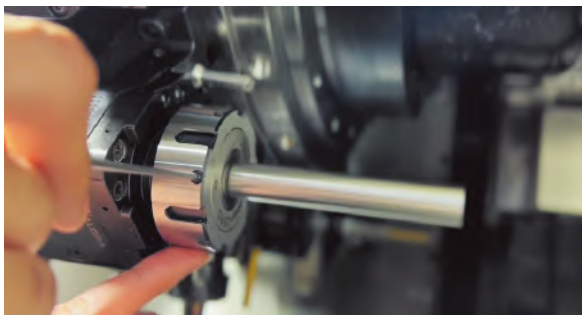
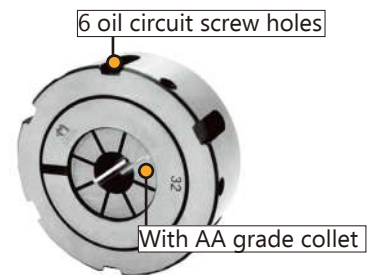

Steps for usage



STEP 1
Loosen and adjust the screws first.



STEP 2
Lock the cutting tool first, and then lock the side adjustment screw.



STEP 3
Measure the current runout accuracy of the tool that needs to be zeroed.



STEP 4
Adjust the runout accuracy of the tool by adjusting the side screw until the desired accuracy is achieved.



STEP 5
Done.

Grippers

Mongtec Grippers — Efficient, Flexible, and Precision-Driven

Powered by either coolant or compressed air, Mongtec grippers offer flexible integration across diverse machining environments. Their modular, plug-and-play design ensures fast installation without additional components, streamlining deployment.

Engineered with a compact claw-style mechanism, the gripper fits closely to the fixture—minimizing bar stock remnants and enhancing material utilization. Ideal for precision machining, it securely clamps hexagonal bar stock with exceptional stability.

Requiring just 0.5 bar of pressure, the gripper operates directly via the machine's coolant line, providing low-pressure actuation for improved efficiency and faster production cycles.

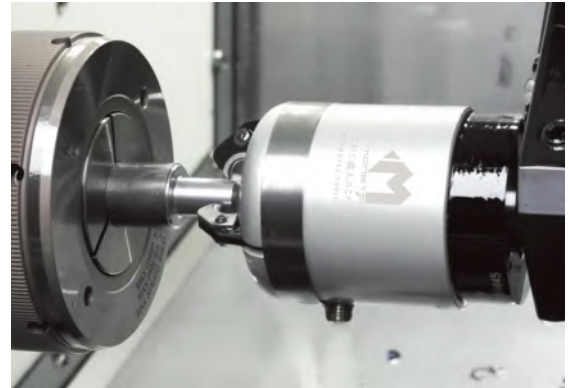

Standard



φ3 : 80 mm

Small



φ2 : 52 mm

Mini



φ0 : 38 mm

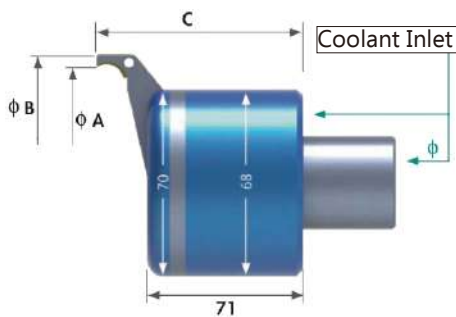

Clamping Force(KG)

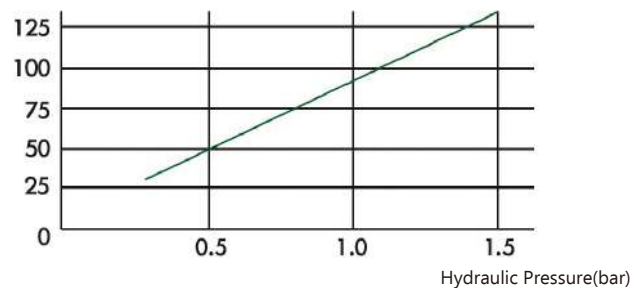

Type

Range	A	B	C	D	L
Standard 3-80mm	83mm	102mm	94mm	68mm	71mm
Small 2-52mm	54mm	74mm	86mm	59mm	64mm
Mini 0-38mm	39mm	52mm	61.5mm	44mm	49.50mm

Spindle Test Bars

Mongtec Spindle Test Bars are high-precision tools specifically designed for multi-tasking machines. They are used to inspect and calibrate spindle accuracy by measuring spindle runout, alignment (horizontal and vertical), thermal expansion, and rigidity—ensuring optimal machining performance.

- **Accuracy:** Runout ≤ 0.003 mm
- **Compatibility:** Available for various spindle interfaces, including BT, BBT, HSK, SK, PSC, VDI, BMT, and ER series
- **Application:** Used for precision spindle inspection and calibration

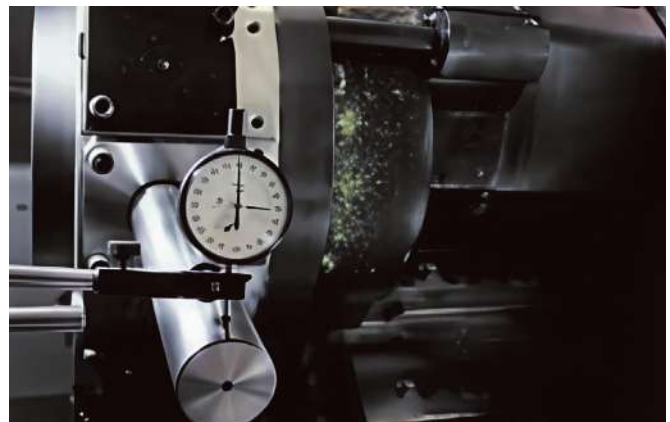

Jet Spindles

Mongtec Jet Spindles boost conventional spindle speeds from 6,000–15,000 rpm to up to 55,000 rpm using hydraulic power (15–70 bar)—reducing machining time by as much as 70%.

Compatible with BT, HSK, ER, PSC, and straight shank interfaces, they integrate seamlessly across various machines and support full ATC automation for rapid, position-free tool changes.

Equipped with a chip-based RPM feedback system, they enable real-time speed monitoring and precise control.

With ± 0.003 mm repeatability, Mongtec Jet Spindles are ideal for micro-machining, high-speed drilling, and other ultra-precision operations.



Micro Jet Spindle

Zero-degree and 90-degree Micro Jet Spindles are compatible with Swiss-type lathes (sliding headstock), gang-type lathes, and turret-type CNC lathes.



Applications of Jet Spindles

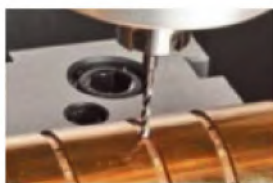

Drilling



Thread Milling



Milling



Precision Engraving



Chamfering



Grinding

CNC Machining Accessories



PSC Turning Tool



HSK Turning Tool



Blank



Pull Stud



Collet Series



Sleeves for boring bars



Z Axial Preset Gauge



Chip Remover



ER Quick Change



Assembly Device



Edge Finder



Stainless Tubes

Maintenance Service

Driven Tools, Angle Heads, Hydraulic Tool Holders

Taiwan Service Center — Expert Repair & Technical Support

Our Taiwan Service Center delivers fast, reliable repair services and in-depth technical support to minimize downtime and keep your equipment operating at peak performance.



Precision Repair Services — Restore Original Performance

Critical components like bearings and bevel gears inevitably wear over time, impacting tool accuracy and system reliability. Mongtec offers premium repair and replacement services to fully restore your equipment's original precision and performance.

As the only provider in the industry using German-certified repair technology, we deliver high-quality, localized maintenance for a wide range of global brands—using imported bearings and precision-

focused processes including:

- Complete disassembly & ultrasonic cleaning
- Certified bearing replacement
- Seal and O-ring renewal
- Precision lubrication
- Expert reassembly & alignment
- Final precision calibration

We support driven toolholders, angle heads, and hydraulic chucks from leading brands such as: Algra, WTO, Heimtec, Eppinger, MT, Evermore, Holdwell, ALPS, OMAP, Mimatic, EWS, Sauter, BIG, Schunk, Sandvik, and more.



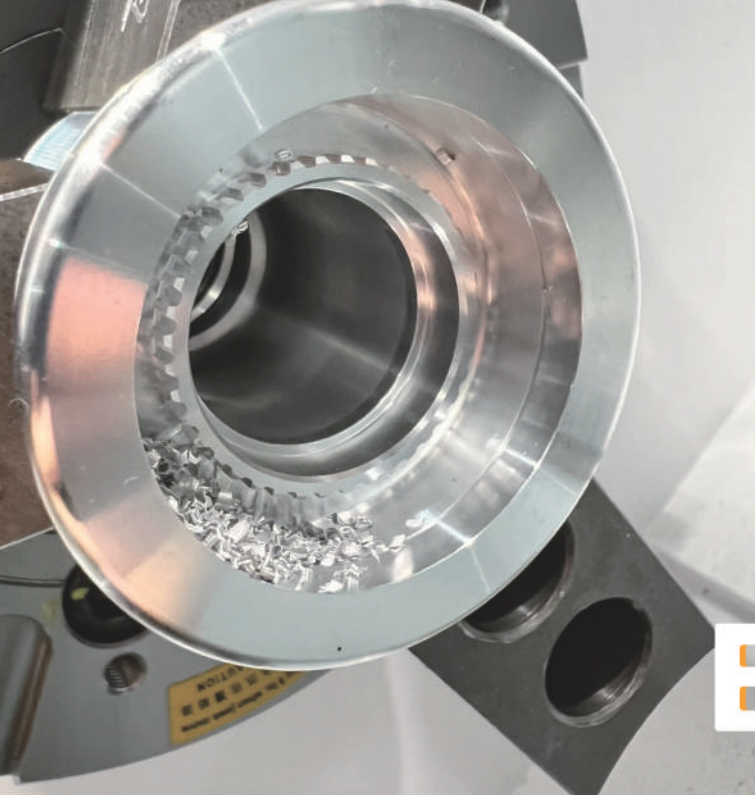

Broaching

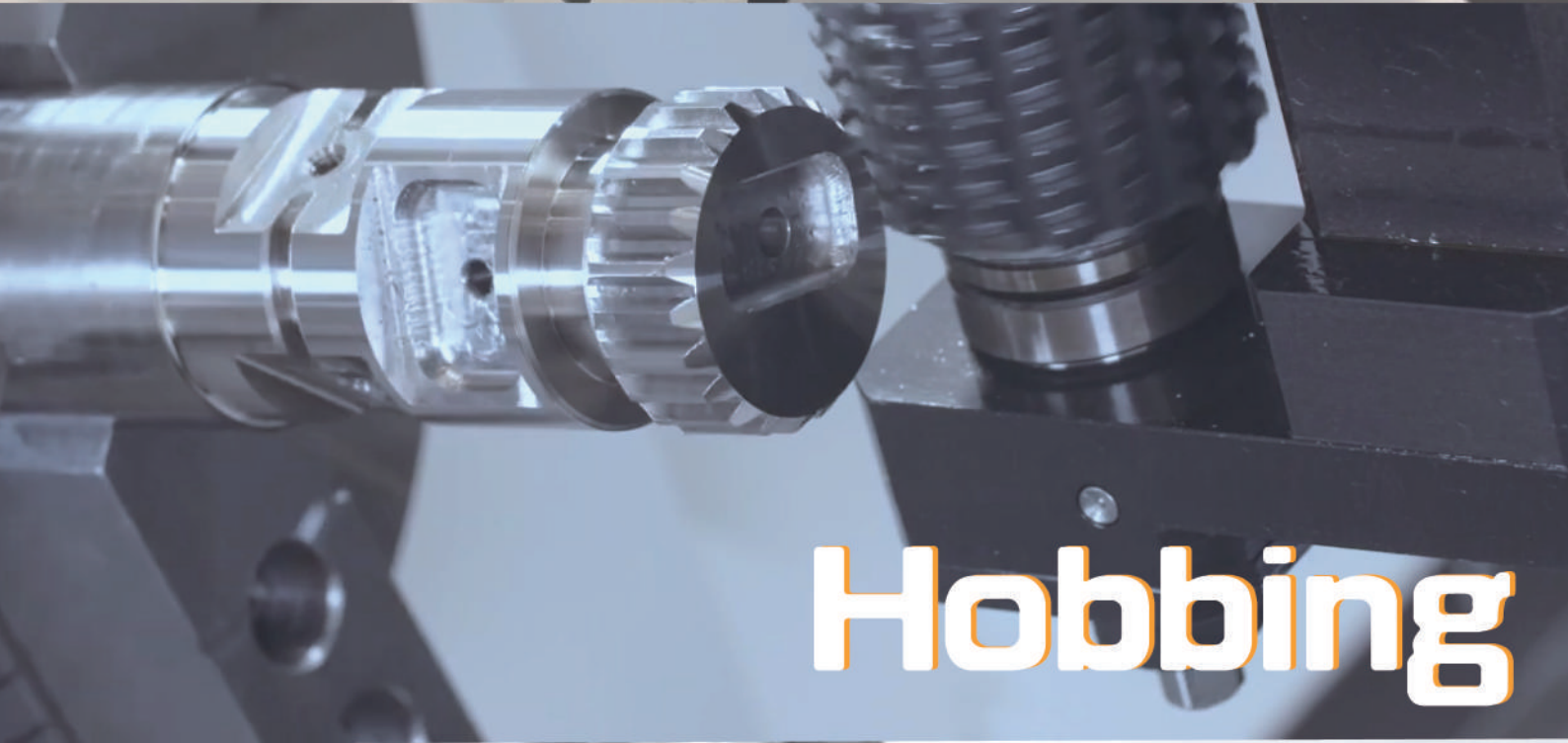

Hobbing



Skiving



Facebook



WeChat



YouTube



Mongtec Web



LINE



Whats App

 **Mongtec Precision Inc.**

TEL : +886-4-22653360

FAX : +886-4-22653386

E-mail : info@mongtec.com

No. 87, Sec. 1, Daqing St., South Dist., Taichung City 40204, Taiwan (R.O.C.)